



Portland, OR  
(503) 688-1231 / (503) 688-1234(FAX)

**13R-150**

**150GPM Fire Pump Package**

**Submittal Packet**

## 13R-150

Compact Residential Package  
Design Condition: 150GPM @ 65PSI

**Please Note:**  
This Talco 13R-Compact package uses a pump that does not carry the UL/FM fire pump listing. Please submit for approval to local AHJ prior to ordering. Submittal packets available at [www.talcofire.com](http://www.talcofire.com)

### System Specifications:

- Motor**
- 10 Horsepower Electric (UL Listed by manufacturer)
  - 230 Volt, 46 Amp
  - Single Phase
  - 3450 RPM

- Pump**
- High pressure cast iron volute
  - Machined bronze impeller
  - 3" Suction
  - 2 1/2" Discharge
  - 150 PSI max working pressure

- Suction Manifold**
- Monitored ball valve (UL Listed by manufacturer)
  - +100 to -30 PSI pressure gauge

- Discharge Manifold**
- Case pressure relief valve (Watts UL Listed)
  - Check Valve
  - Zero to 160 PSI pressure gauge
  - Flow switch (Potter UL Listed)
  - Monitored ball valve (UL Listed by manufacturer)

- Controls**
- UL Listed Eaton FDR Residential Controller
  - Hard copper sensing line (per NFPA 20)

- Dimensions**
- 34 1/16" Length
  - 48" Height
  - 22" Width
  - 320 pounds

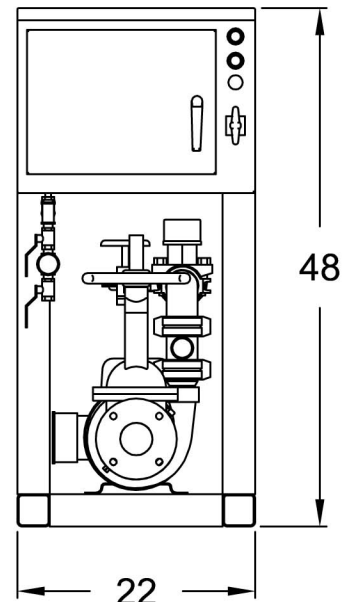
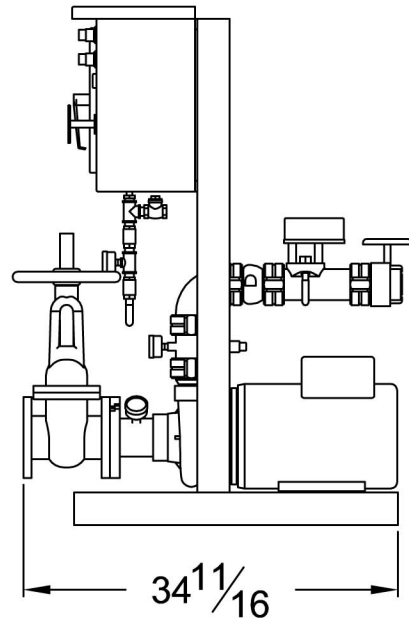

## Performance

Performance values based on multiple pump tests. Not for certification purposes.

GPM	0	60	90	110	150	180	200	225
PSI	72	72	71	70	67	64	62	57

# TALCO 13R-150

## PUMP DATA

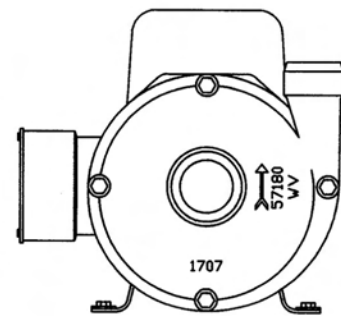
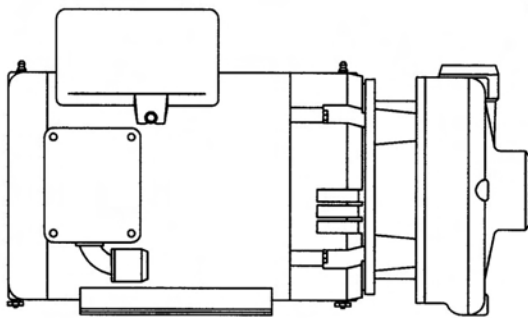
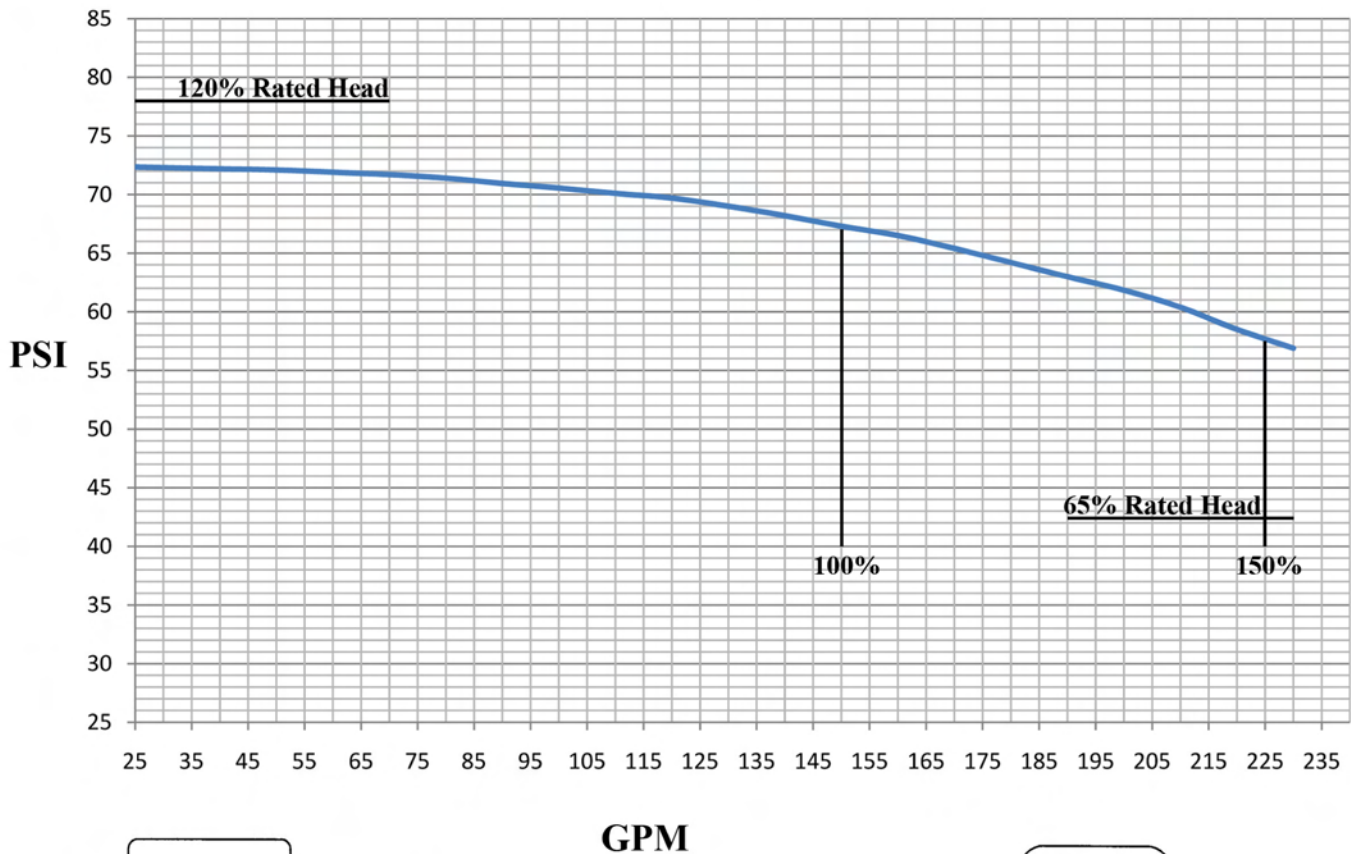

### System Specifications

- Motor-
- 10 HP Electric
  - 230 Volt, 46 Amp
  - Single Phase
  - 3450 RPM
  - JM Frame
  - Shaft Sleeve/O-ring for  
Protection Against Shaft Damage
  - Sealed Motor Bearings to Carry  
Axial & Thrust Loads
  - Open Drip Proof

- Pump-
- High Pressure Cast-Iron Volute
  - Machined Bronze Impeller
  - 3" Suction
  - 2" Discharge
  - 150 PSI Max Working Pressure

March 2008

## FDR Residential - Simplex, Duplex



## Product Description

Eaton Cutler-Hammer Residential Fire Pump Controllers work in conjunction with single phase, electric, residential fire pumps and packages. Available as a Simplex or Duplex unit, all controllers are UL listed and meet or exceed NEMA requirements.

## Product Features

### Sequential Start Timer

A sequential start timer may be installed which is used to program a start delay after the pressure switch initiates an automatic start. In duplex controllers, a SST is standard and is wired to delay starting the second (lag) pump. The timer does not operate if starting is initiated via the start pushbutton or emergency start handle.



### Run Period Timer

The run period timer turns on whenever the controller starts due to a drop in pressure. This ensures that the pump motor is not subjected to frequent starts if the pressure switch contact repeatedly closes and opens at short time intervals because of pressure fluctuations.

### NEMA 2 Enclosures

All FDR controllers are supplied with NEMA 2 enclosures. Contact factory for availability of other styles.

### Alarm & Status Indication

Both Simplex and Duplex controllers are equipped with illuminated pushbuttons which have dual use. The green "POWER ON" pushbutton functions as the "Start" pushbutton and indicates when the circuit breaker is closed. The red "PUMP RUNNING" pushbutton functions as the "Stop" pushbutton and indicates when the pump is running.



When the controller starts the fire pump, the red Pump Running light turns on as well as the buzzer mounted on the front panel.

### Mounting Bars

Each FDR residential controller is equipped with upper and lower mounting bars as standard.



### Optional Floor Mount Legs

Optional 12 inch high floor mounting legs are available upon request.

### Dual Setting Pressure Switch

A dual setting 15-290 PSI pressure switch is used to sense a drop in pressure which actuates the residential controller. The setting adjustment screws are used for setting the pressure range and differential. There is one set of form-C output contacts rated at 10 amps.



### NEMA Rated Contactors

Cutler-Hammer NEMA rated Freedom Contactors are used in all FDR Residential fire pump controllers. A wide variety of coil voltages are available for domestic and international use.

### Emergency Start Operator

A mechanically operated emergency start handle activates the motor contactor independent of any electrical control circuits or pressure switch input.

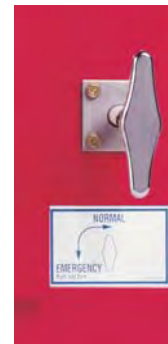

## Standards & Certification

The FDR Residential Fire Pump Controllers meet or exceed the requirements of Underwriters Laboratories, Underwriters Laboratories Canada, the Canadian Standards Association, and the New York City building code.



N. Y. C.  
APPROVED

FDR Residential - Simplex, Duplex

**Dimensions**

**Standard Enclosure - Simplex - Type NEMA 2**

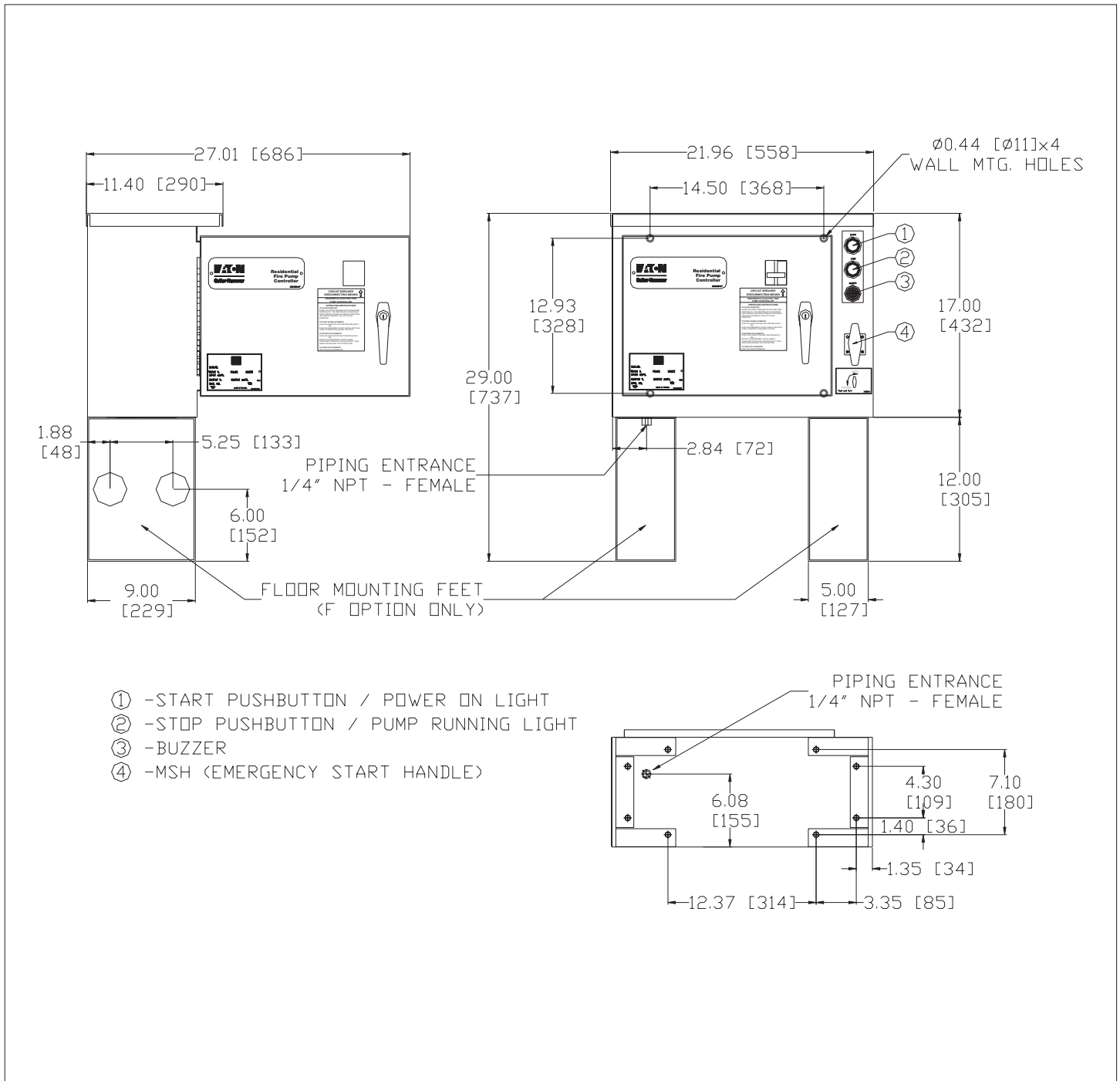

Motor Hp	Line Voltage	Withstand Rating		Approx. Weight Lbs. (Kg)
		Standard	Intermediate	
½ - 10	230V - Single Phase	10,000	22,000	60 (27)

NOTES:

1. All enclosures finished in FirePump red.
2. Cable Entrance either top or bottom.
3. Standard Enclosure type NEMA 2.
4. Add 12" height for optional floor stands.



**Electrical Wiring Schematic**  
FDR Residential - Simplex

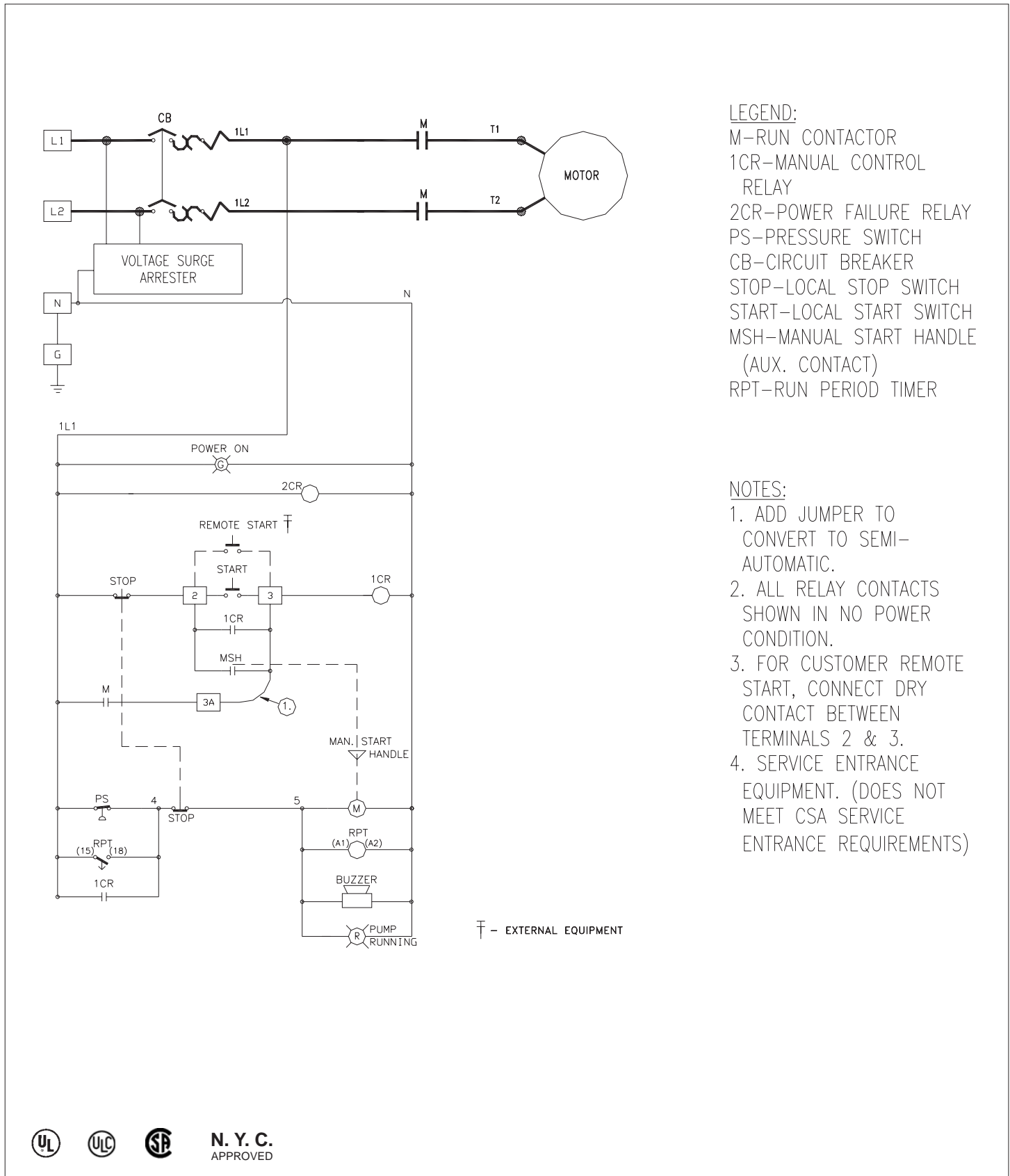

# NFPA-20 Pressure Sensing Line Detail

To Control Panel  
Pressure Switch

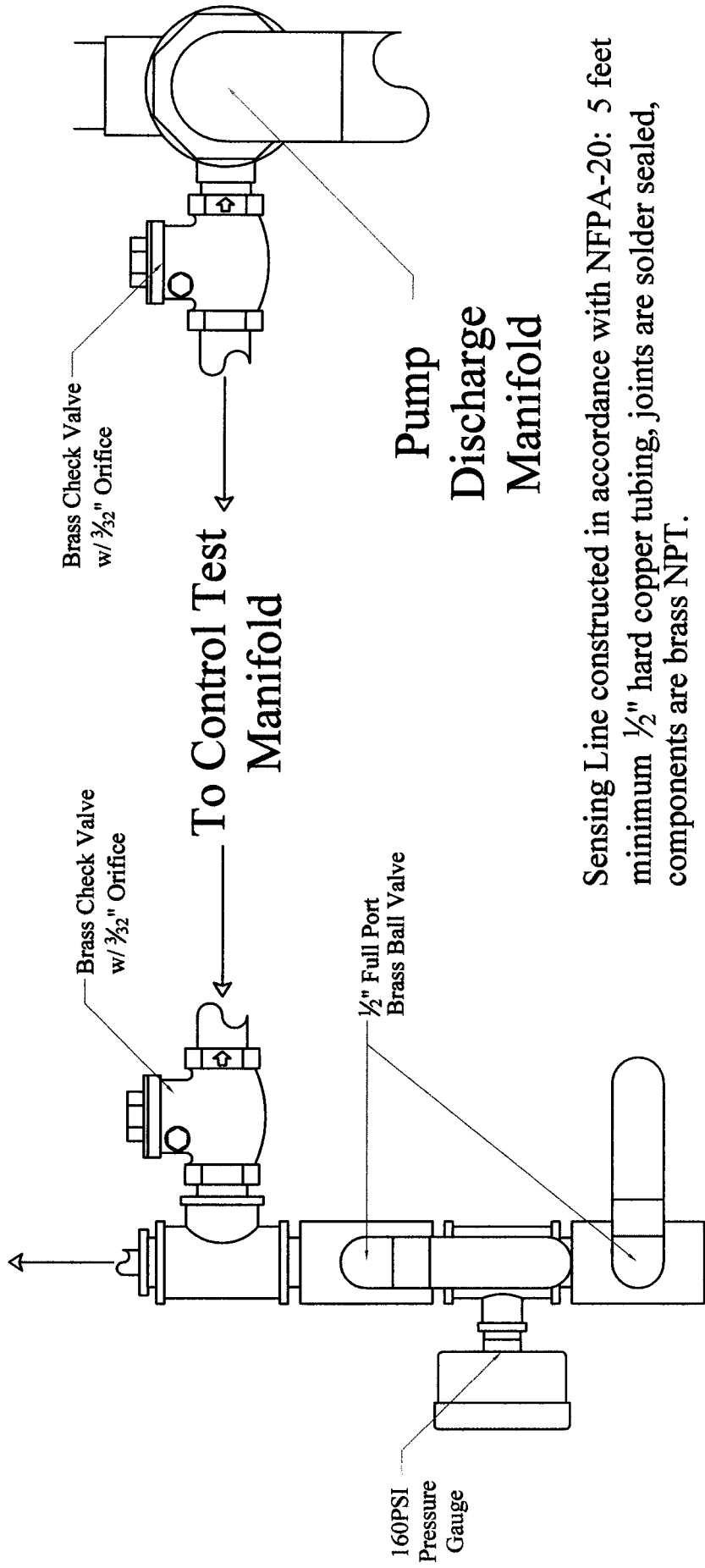

Sensing Line constructed in accordance with NFPA-20: 5 feet minimum 1/2" hard copper tubing, joints are solder sealed, components are brass NPT.

# Valves and Accessories

## FireLock Ball Valve

### SERIES 728

For Complete Information  
Request Publication 10.17

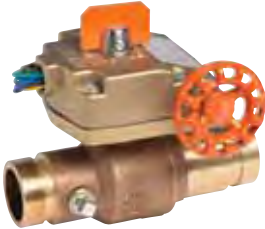

SERIES 728 GROOVED

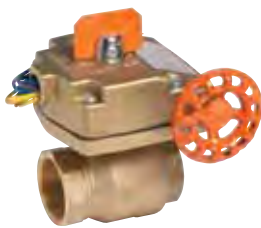

SERIES 728 THREADED

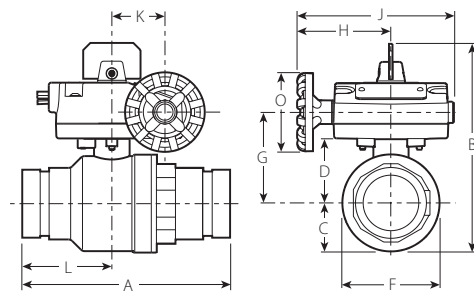

GROOVED x GROOVED  
TYPICAL OF ALL SIZES

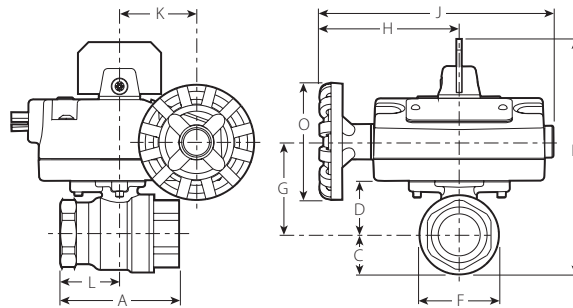

THREADED x THREADED  
TYPICAL OF ALL SIZES



- Standard port, end-entry valve
- Available with grooved or threaded ends (NPT)
- Approved for indoor and outdoor use
- Pressure rated up to 350 psi/2400 kPa
- Sizes from 1¼ – 2¾/32 – 50 mm for grooved sizes
- Sizes from 1 – 2¾/25 – 50 mm for threaded sizes

Size		Dimensions												Approx. Wgt.	
Nominal Size	Actual Out. Dia.	A	B	C	D	F	G	H	J	K	L	O	Lbs.	kg	
Inches	mm	E to E	Height	Inches	Inches	Inches	Inches	Inches	Inches	Inches	Inches	Inches			
mm	mm	mm	mm	mm	mm	mm	mm	mm	mm	mm	mm	mm			

#### GROOVED x GROOVED

1¼	1.660	7.25	6.25	1.15	1.67	2.30	2.58	3.39	5.62	1.86	3.19	2.75	7.5	3.4
32	42.2	184	159	29	42	58	66	86	143	47	81	67		
1½	1.900	7.25	6.75	1.35	1.89	2.71	2.80	3.39	5.62	1.86	3.19	2.75	8.5	3.9
40	48.3	184	171	34	48	69	71	86	143	47	81	67		
2	2.375	7.25	7.50	1.71	2.25	3.16	3.50	3.39	5.62	1.86	3.19	2.75	10.5	4.8
50	60.3	184	191	43	57	80	89	86	143	47	81	67		

#### THREADED x THREADED

1	1.315	2.84	5.61	0.93	1.22	1.87	2.27	3.39	5.62	1.86	1.42	2.75	5.1	2.3
25	33.4	72	143	24	31	48	58	86	143	47	36	67		
1¼	1.660	3.31	6.04	1.15	1.53	2.30	2.47	3.39	5.62	1.86	1.65	2.75	5.8	2.6
32	42.2	84	153	29	39	58	63	86	143	47	42	67		
1½	1.900	3.66	6.42	1.35	1.71	2.66	2.66	3.39	5.62	1.86	1.83	2.75	6.6	3.0
40	48.3	92	163	34	43	68	68	86	143	47	47	67		
2	2.375	4.33	7.15	1.71	2.07	3.40	3.05	3.39	5.62	1.86	2.16	2.75	8.5	3.9
50	60.3	110	182	43	53	86	77	86	143	47	55	67		

## SWITCH AND WIRING

### Supervisory Switch

The supervisory switch contains two, single pole, double throw, pre-wired switches.

Switches are rated:

- 10 amps @ 125 or 250 VAC/60 Hz
- 0.50 amps @ 125 VDC
- 0.25 amps @ 250 VDC
- 2.6 amps @ 24 VDC

### Supervisory Switch Wiring

#### A. Pre-wired Switches

(1) Switches supervise valve in "open" position

(2) One switch has two #18 MTW wires per terminal, which permit complete supervision of leads (refer to diagrams and note below). The second switch has one #18MTW wire per terminal. This double circuit provides flexibility to operate two electrical devices at separate locations, such as an indicating light and an audible alarm, in the area that the valve is installed.

(3) A #14MTW ground lead(green) is provided

- |    |           |                           |
|----|-----------|---------------------------|
|    | Switch #1 | S1                        |
|    | Switch #2 | S2                        |
| S1 | {         | Normally Closed: (2) Blue |
|    |           | Normally Open: (2) Brown  |
|    |           | Common: (2) Yellow        |
| S2 | {         | Normally Closed:          |
|    |           | Blue with Orange Stripe   |
|    |           | Normally Open:            |
|    |           | Brown with Orange Stripe  |
|    |           | Common:                   |
|    |           | Yellow with Orange Stripe |

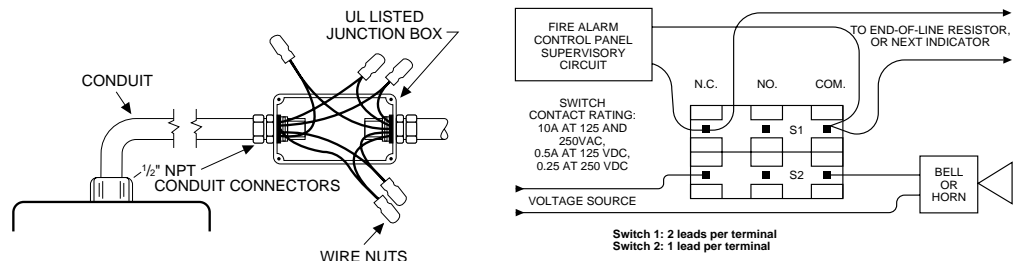

**NOTE:** The above diagram shows a connection between the common terminal (yellow-S1) and yellow-with-orange stripe-S2) and the normally closed terminal (blue-S1 and blue-with-orange stripe-S2). In this example, the indicator light and alarm will stay on until the valve is fully open. When the valve is fully open, the indicator light and alarm will go out. Cap off any unused wires (e.g. brown and brown with orange stripe).

## MATERIAL SPECIFICATIONS

**Valve Body:** Bronze ASTM B-584 Alloy 844

**Ball:** Chrome Plated Brass

**Stem:** 316 Stainless Steel

**Seat:** (TFE) tetrafluoroethylene

**Stem Nut:** Brass ASTM B-16 C36000

**Quadrant Gear:** 316 Stainless Steel

**Main Stem:** Brass ASTM B16 C36000

**Worm Gear:** AISI 1144 Steel

This product shall be manufactured by Victaulic Company. All products to be installed in accordance with current Victaulic installation/assembly instructions. Victaulic reserves the right to change product specifications, designs and standard equipment without notice and without incurring obligations.



Stock No. 1144440

**⚠ WARNING**

Installation must be performed by qualified personnel and in accordance with all national and local codes and ordinances.

Shock hazard. Disconnect power source before servicing. Serious injury or death could result.

Risk of explosion. Not for use in hazardous locations. Serious injury or death could result.

**UL, ULC, CSFM Listed and NYMEA Accepted**

**Service Pressure:** Up to 300 PSI (20,7 BAR)

**Flow Sensitivity Range for Signal:** 4-10 GPM (15-38 LPM) UL

**Maximum Surge:** 18 FPS (5,5 m/s)

**Enclosure:** Die-cast, red enamel finish  
Cover held in place with tamper resistant screws

**Contact Ratings:** Two sets of SPDT (Form C)  
10.0 Amps at 125/250 VAC  
2.0 Amps at 30 VDC Resistive  
10mAmps min. at 24 VDC

**Conduit Entrances:** Two openings provided for 1/2" conduit.  
Individual switch compartments suitable for dissimilar voltages.

**Usage:** Listed plastic, copper and schedule 40 iron pipe.  
Fits pipe sizes - 1" (25mm), 1 1/4" (32mm), 1 1/2" (38mm) and 2" (50mm)  
Note: 12 paddles are furnished with each unit, one for each pipe size of threaded and sweat TEE, one for 1" (25mm) CPVC, one for 1" (25mm) CPVC (Central), one for 1" threaded Nibco CPVC, and one for 1 1/2" (38mm) threaded (Japan).

**Environmental Specifications:**

- NEMA-4/IP54 Rated enclosure suitable for indoor or outdoor use with factory installed gasket and die-cast housing when used with appropriate conduit fitting.
- Temperature range: 40° F to 120° F, (4,5° C to 49° C) UL

**Service Use:**

Automatic Sprinkler	NFPA-13
One or two family dwelling	NFPA-13D
Residential occupancy up to four stories	NFPA-13R
National Fire Alarm Code	NFPA-72

**Optional:** Cover Tamper Switch Kit, Stock No. 0090148  
(See Fig. 7 for terminations)

**Replaceable Components:** Retard/Switch Assembly, stock no. 1029030

The Model VSR-S is a vane type waterflow switch for use on wet sprinkler systems that use 1" (25mm), 1 1/4" (32mm), 1 1/2" (38mm) or 2" (50mm) pipe size. The unit may also be used as a sectional waterflow detector on large systems.

The unit contains two single pole double throw snap action switches and an adjustable, instantly recycling pneumatic retard. The switches are actuated when a flow of 10 gallons per minute (38 LPM) or more occurs downstream of the device. The flow condition must exist for a period of time necessary to overcome the selected retard period.

**Enclosure**

The VSR-S switches and retard device are enclosed in a general purpose, die-cast housing. The cover is held in place with two tamper resistant screws which require a special key for removal. A field installable cover tamper switch is available as an option which may be used to indicate unauthorized removal of the cover. See bulletin number 5401103 for installation instructions of this switch.

**Installation**

These devices may be mounted in horizontal or vertical pipe. On horizontal pipe they should be installed on the top side of the pipe where they will be accessible. The units should not be installed within 6" (15cm) of a valve, drain or fitting which changes the direction of the waterflow. Select the proper paddle for the pipe size and type of TEE used see Fig. 1 for instructions on changing paddle. The unit has a 1" NPT bushing for threading into a non-corrosive TEE. See Fig. 2 for proper TEE size, type and installation. Use no more than three wraps of teflon tape.

Screw the device into the TEE fitting as shown in Fig. 2. Care must be taken to properly orient the device for the direction of waterflow.

The vane must not rub the inside of the TEE or bind in any way. The stem should move freely when operated by hand.

The device can also be used in copper or plastic pipe installations with the proper adapters so that the specified TEE fitting may be installed on the pipe run.

**Note:** Do not leave cover off for an extended period of time.