

TALCO

Fire Systems

FFX NitroPower Fire Water System

Talco FFX NitroPower packaged systems are designed to provide fire protection even if reliable power is not available. Our standard system provides 300 gallons of stored water delivered at up to 60 GPM with no electricity or diesel fuel needed.

System pressure is easily adjustable from 20 to well in excess of 100 PSI.

FFX packages are scalable, multiple water tanks and pressure cylinders may be combined to meet any design condition.

FFX systems require little-to-no regular maintenance. Once properly installed they are primed and ready to go for the duration of their service life

With hundreds of installations over the last 15 years, Talco will get you up and running with an easy to install, trouble free FFX NitroPower System.

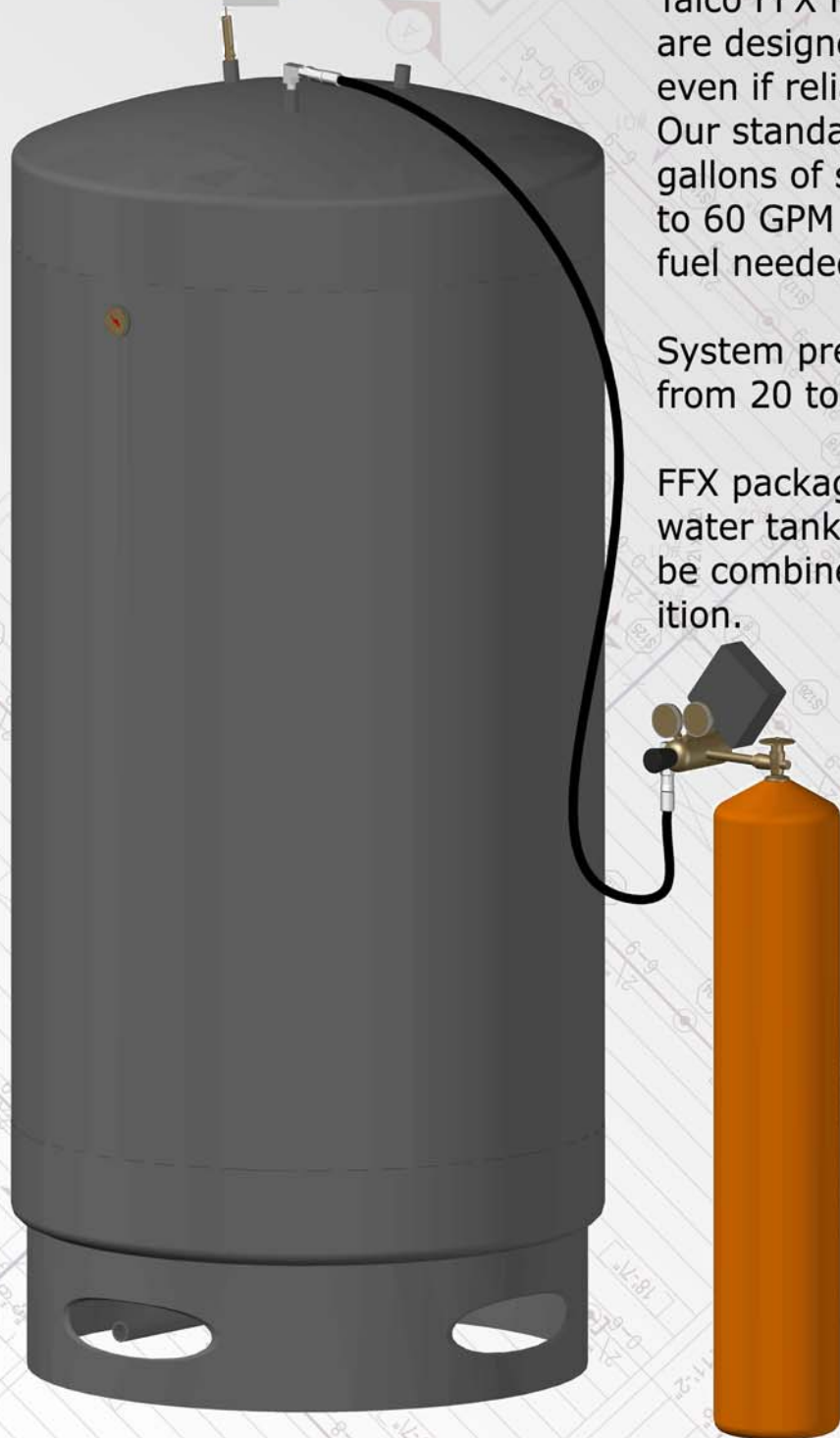

AURORA - GOULDS - FRANKLIN - CLARKE - CUMMINS - TORNATECH - METRON - EATON

TALCO

Fire Systems

FFX NitroPower Packaged Systems

System Components:

- Premium Brass Regulator
- Zero Leakage Relief Valve
- Compressed Nitrogen Gas Cylinder
- Fabricated Steel Water Pressure Tank (ASME Certified)
- Water Level Gauge
- Brass Check Valve
- Discharge Manifold and Fittings
- Mounting Hardware
- Anti-Microbial Water Treatment

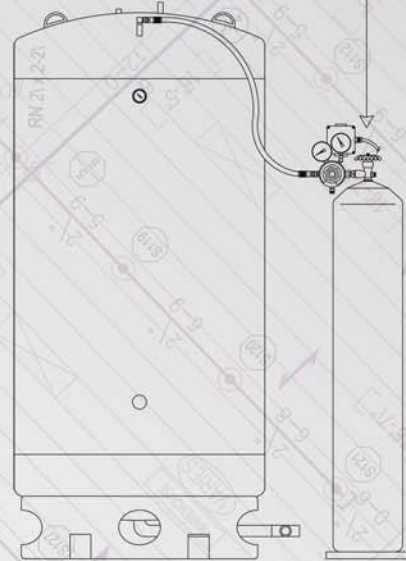
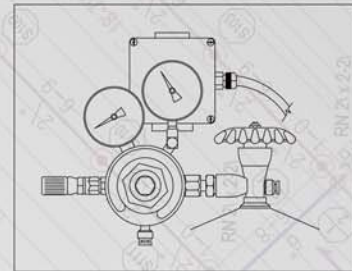

3500 Gallon - 350GPM@75PSI Fire Protection System

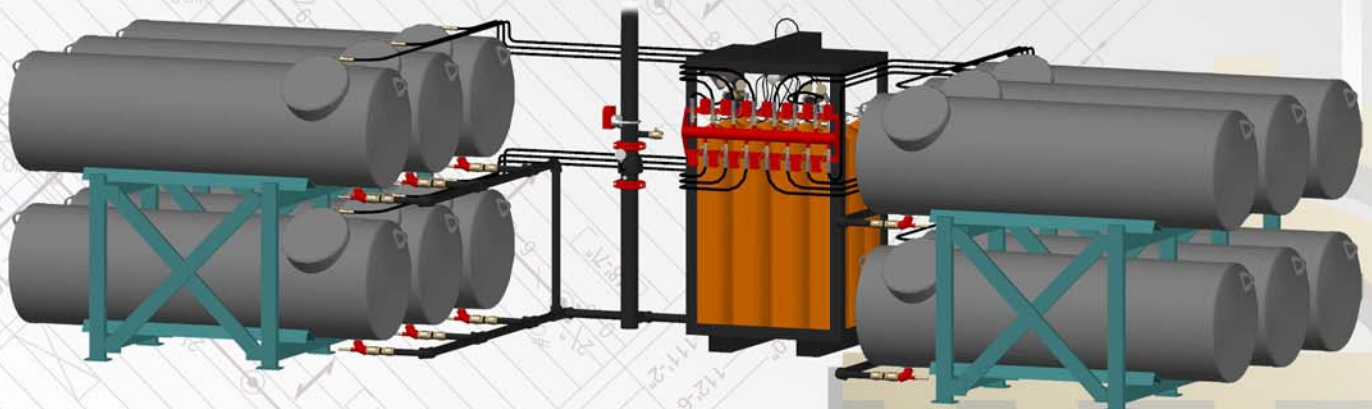

DIESEL - ELECTRIC - INLINE - SPLIT CASE - CENTRIFUGAL - TURBINE - SUBMERSIBLE

Talco Fire Systems

Residential & Commercial Packaged Fire Pump Specialists

Portland, Oregon

FFX-30 NitroPower Residential Fire Water Supply System

Low Maintenance
No Power Required
25 to 100 PSI Adjustable Pressure
30 GPM (Set for 10 minute run time)

System Components:

- Premium Brass Regulator
- Zero Leakage Relief Valve
- Nitrogen Gas Cylinder
- Fabricated Steel Water Pressure Tank (ASME Certified)
- Water Level Gauge
- Brass Check Valve
- Discharge Manifold & Fittings
- Mounting Hardware

Dimensions:

- Discharge Pipe Size: 1" NPT
- Water Tank: 300 gallon
36" Diameter x 73" Tall
- Nitrogen Tank: 336ci.
11" Diameter x 62" Tall
- Pad Size: 54" x 54" (Recommended)
- Weight: 800# (Dry)

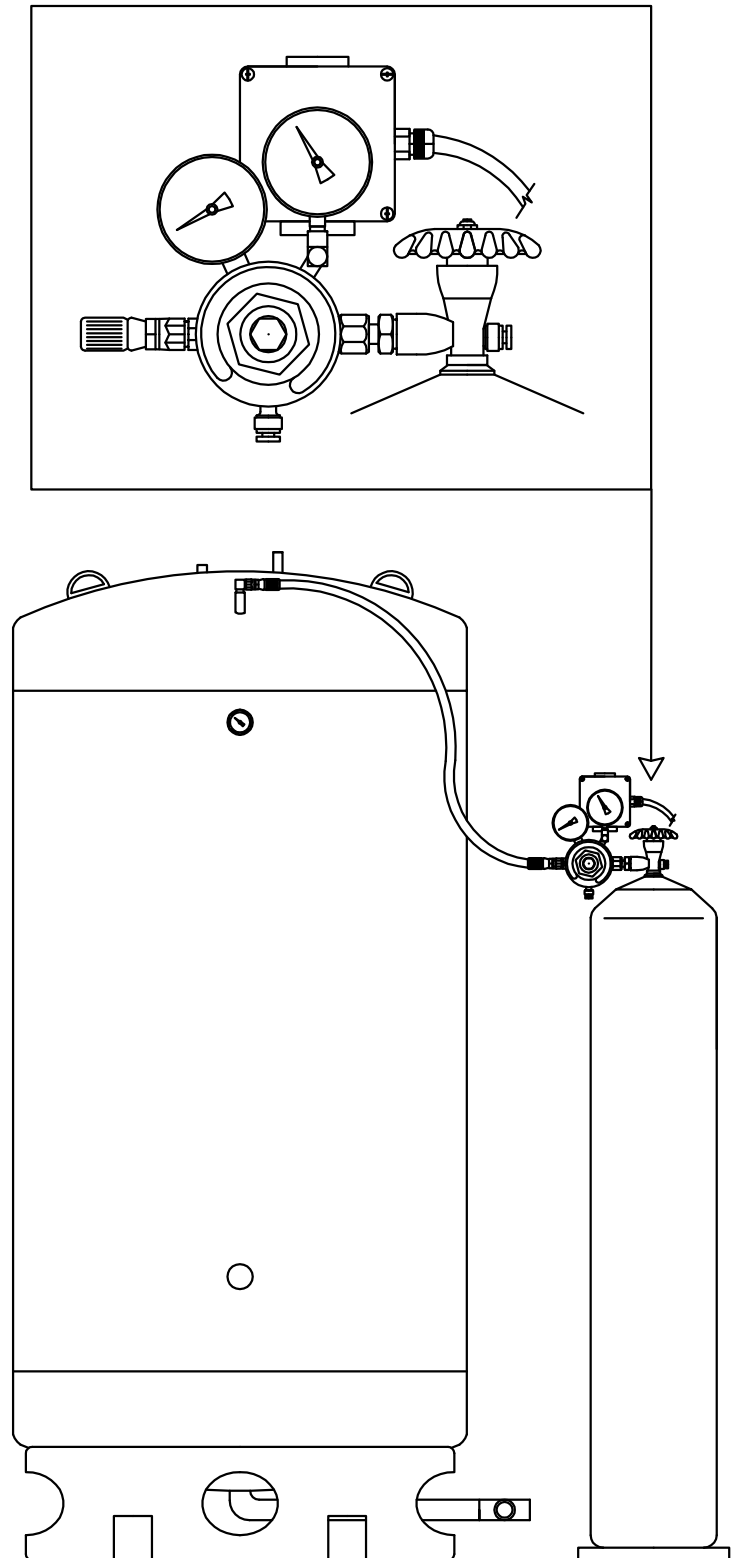

Talco Fire Systems

Residential & Commercial Packaged Fire Pump Specialists

Portland, Oregon

FFX-45 NitroPower Residential Fire Water Supply System

Low Maintenance
No Power Required
25 to 100 PSI Adjustable Pressure
45 GPM (Set for 10 minute run time)

System Components:

- Premium Brass Regulator
- Zero Leakage Relief Valve
- Nitrogen Gas Cylinder
- Fabricated Steel Water Pressure Tank (ASME Certified)
- Water Level Gauge
- Brass Check Valve
- Discharge Manifold & Fittings
- Mounting Hardware

Dimensions:

- Discharge Pipe Size: 1 1/4" NPT
- Water Tank: 450 gallon
42" Diameter x 82" Tall
- Nitrogen Tank: 336ci. (Quantity - 2)
11" Diameter x 62" Tall
- Pad Size: 72" x 72" (Recommended)
- Weight: 1100# (Dry)

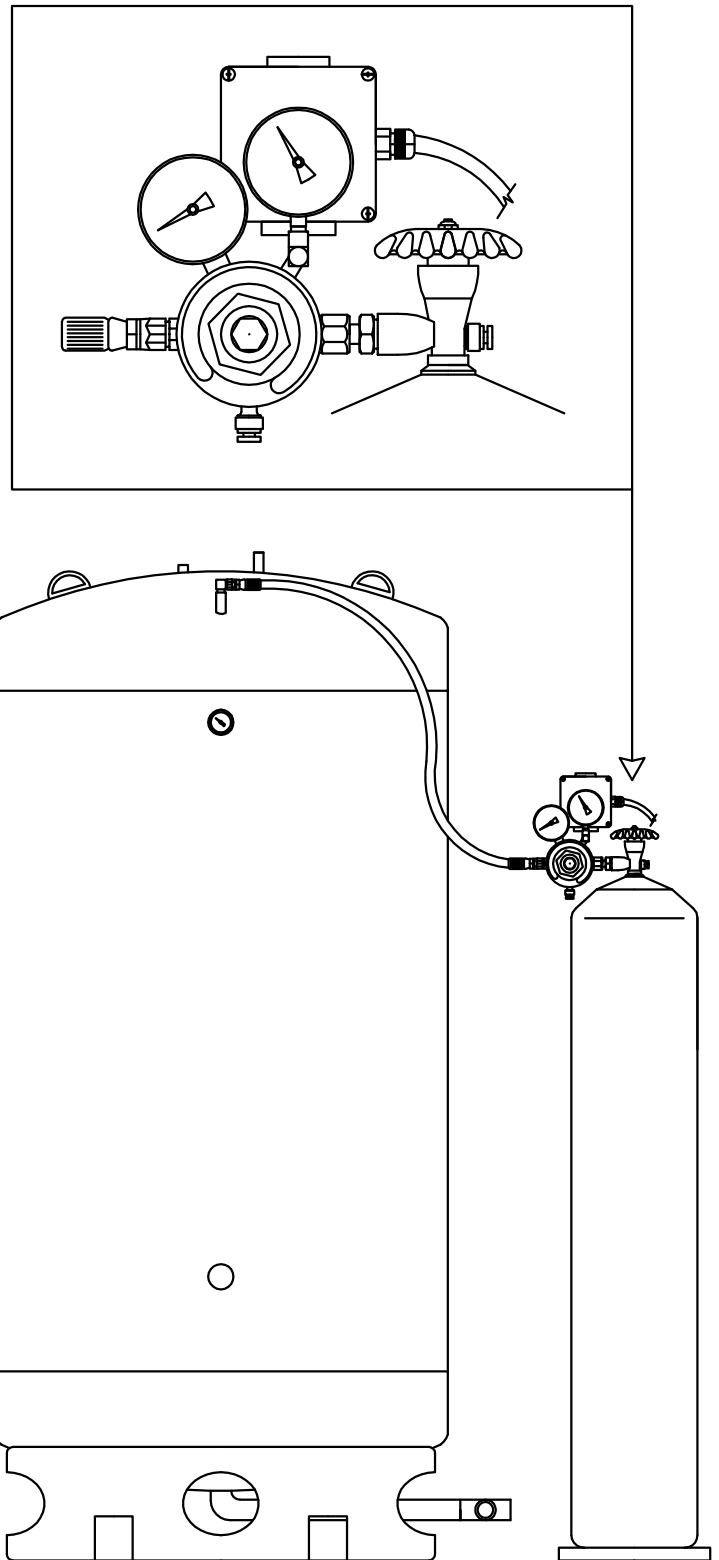

Talco Fire Systems

Residential & Commercial Packaged Fire Pump Specialists

Portland, Oregon

FFX-60 NitroPower Residential Fire Water Supply System

Low Maintenance
No Power Required
25 to 100 PSI Adjustable Pressure
60 GPM (Set for 10 minute run time)

System Components:

- Premium Brass Regulator
- Zero Leakage Relief Valve
- Nitrogen Gas Cylinder
- Fabricated Steel Water Pressure Tank (ASME Certified)
- Water Level Gauge
- Brass Check Valve
- Discharge Manifold & Fittings
- Mounting Hardware

Dimensions:

- Discharge Pipe Size: 1 ¼" NPT
- Water Tank: 600 gallon
48" Diameter x 86" Tall
- Nitrogen Tank: 336ci. (Quantity - 2)
11" Diameter x 62" Tall
- Pad Size: 90" x 90" (Recomended)
- Weight: 1400# (Dry)

