

Talco Fire Systems

Residential & Commercial Packaged Fire Pump Specialists

Portland, Oregon

ULR-200

w/Test Port, City By-Pass, Jockey Pump
Listed Fire Pump & Controller
NFPA-20 Compliant Packaged System

Controller: _____

Jockey Pump: _____

Jockey Controller: _____

Suction x Discharge: 3" x 3" Grooved Fittings

200GPM

3 x 3 - 9A

PSI (range)	Motor HP
55-75	15
76-100	20
101-115	25
116-125	30
126-155	40
156-159	50

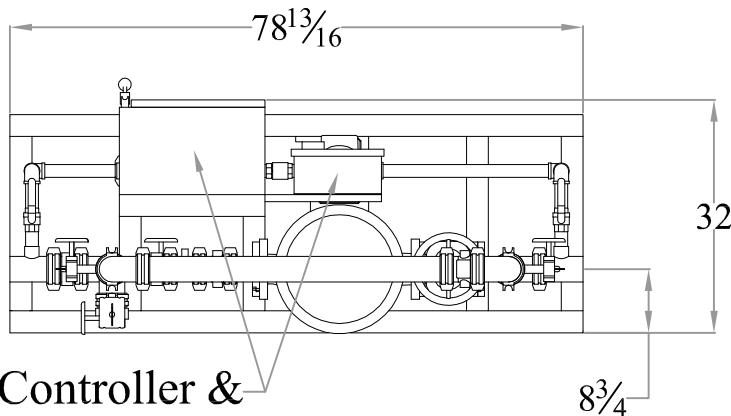

Main Controller &
Jockey Controller

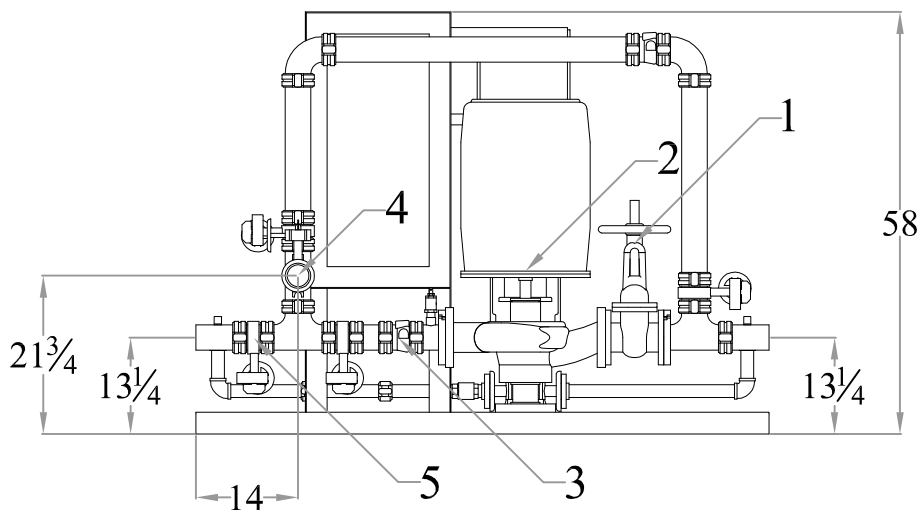

DESIGN CONDITIONS

_____ GPM @ _____ PSI
_____ HP _____ V _____ Phase

Project: _____

Contractor: _____

Date: _____

P.O.: _____

System Components

1	OS&Y Gate Valve
2	Inline Pump & Motor
3	Check Valve
4	Test Port Connection
5	Monitored Butterfly

Approximate ship weight: < 1200#

Phone: (800) 878-8055

www.talcofire.com

Fax: (503) 688-1234