

# Talco Fire Systems

Residential & Commercial Packaged Fire Pump Specialists

Portland, Oregon

## ULR-250

w/Flow Meter, Jockey Pump  
Listed Fire Pump & Controller  
NFPA-20 Compliant Packaged System

Controller: \_\_\_\_\_

Jockey Pump: \_\_\_\_\_

Jockey Controller: \_\_\_\_\_

Suction x Discharge: 4" x 3" Grooved Fittings

## 250GPM

3 x 4 - 9

PSI (range)	Motor HP
66-85	20
86-100	25
101-115	30
116-135	40
136-138	50

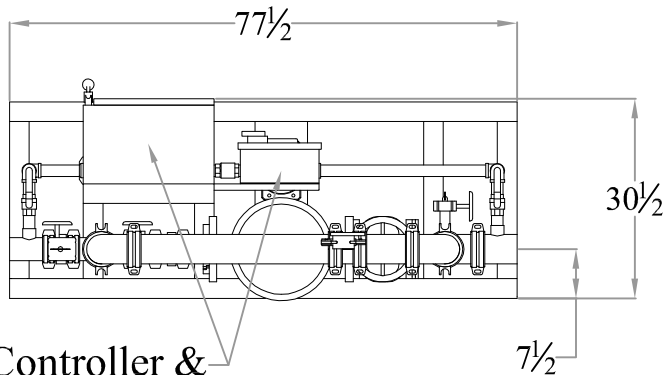

Main Controller &  
Jockey Controller

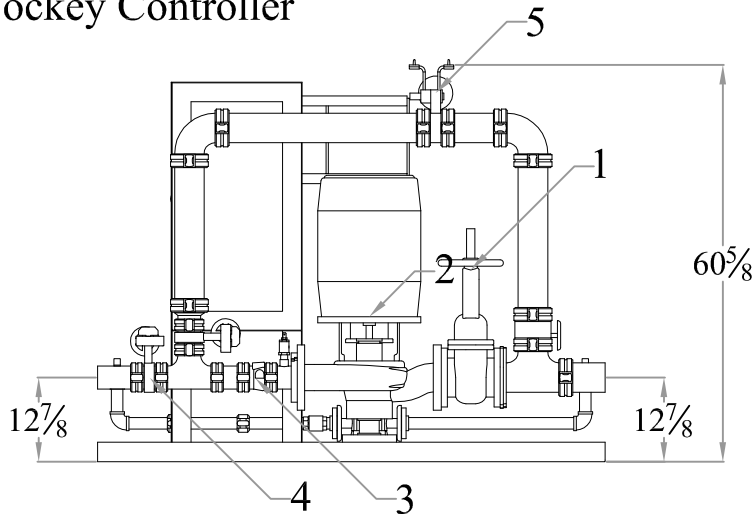

### DESIGN CONDITIONS

\_\_\_\_\_ GPM @ \_\_\_\_\_ PSI  
\_\_\_\_\_ HP \_\_\_\_\_ V \_\_\_\_\_ Phase

Project: \_\_\_\_\_

Contractor: \_\_\_\_\_

Date: \_\_\_\_\_ P.O.: \_\_\_\_\_

### System Components

1	OS&Y Gate Valve
2	Inline Pump & Motor
3	Check Valve
4	Monitored Butterfly
5	Flow Meter

Approximate ship weight: < 1250#

Phone: (800) 878-8055

www.talcofire.com

Fax: (503) 688-1234