

Talco Fire Systems

Residential & Commercial Packaged Fire Pump Specialists

Portland, Oregon

ULR-300

w/Test Port, Jockey Pump
Listed Fire Pump & Controller
NFPA-20 Compliant Packaged System

Controller: _____

Jockey Pump: _____

Jockey Controller: _____

Suction x Discharge: 4" x 4" Grooved Fittings

300GPM

4 x 4 - 7B

| PSI (range) | Motor HP |
|----------------|-------------|
| 42-45 | 15 |
| 46-55 | 20 |
| 56-65 | 25 |
| 66-73 | 30 |

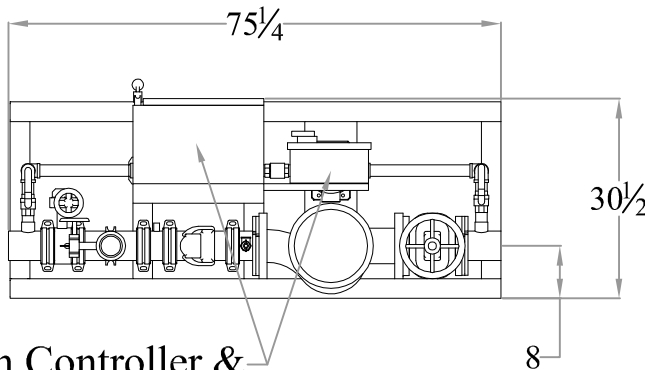

Main Controller &
Jockey Controller

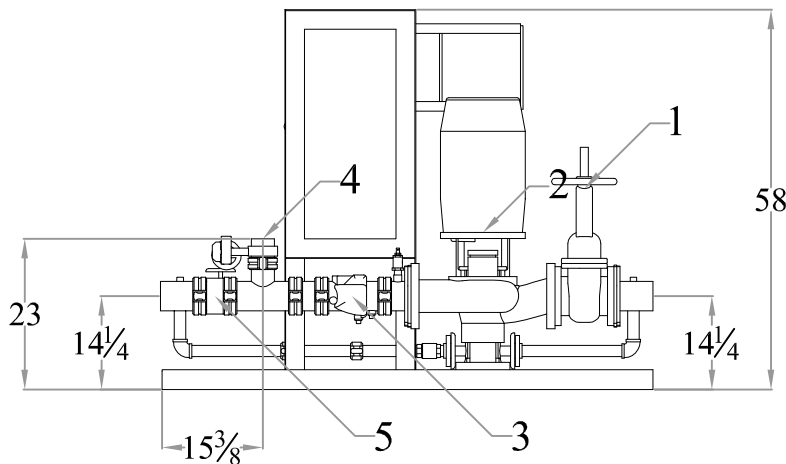

| DESIGN CONDITIONS | |
|------------------------------|--|
| _____ GPM @ _____ PSI | |
| _____ HP _____ V _____ Phase | |

| | |
|-------------------|-------------|
| Project: _____ | |
| Contractor: _____ | |
| Date: _____ | P.O.: _____ |

| System Components | |
|-------------------|----------------------|
| 1 | OS&Y Gate Valve |
| 2 | Inline Pump & Motor |
| 3 | Check Valve |
| 4 | Test Port Connection |
| 5 | Monitored Butterfly |

Approximate ship weight: < 1200#