

# TALCO

## Fire Systems

### Underground Residential Fire Pump Systems

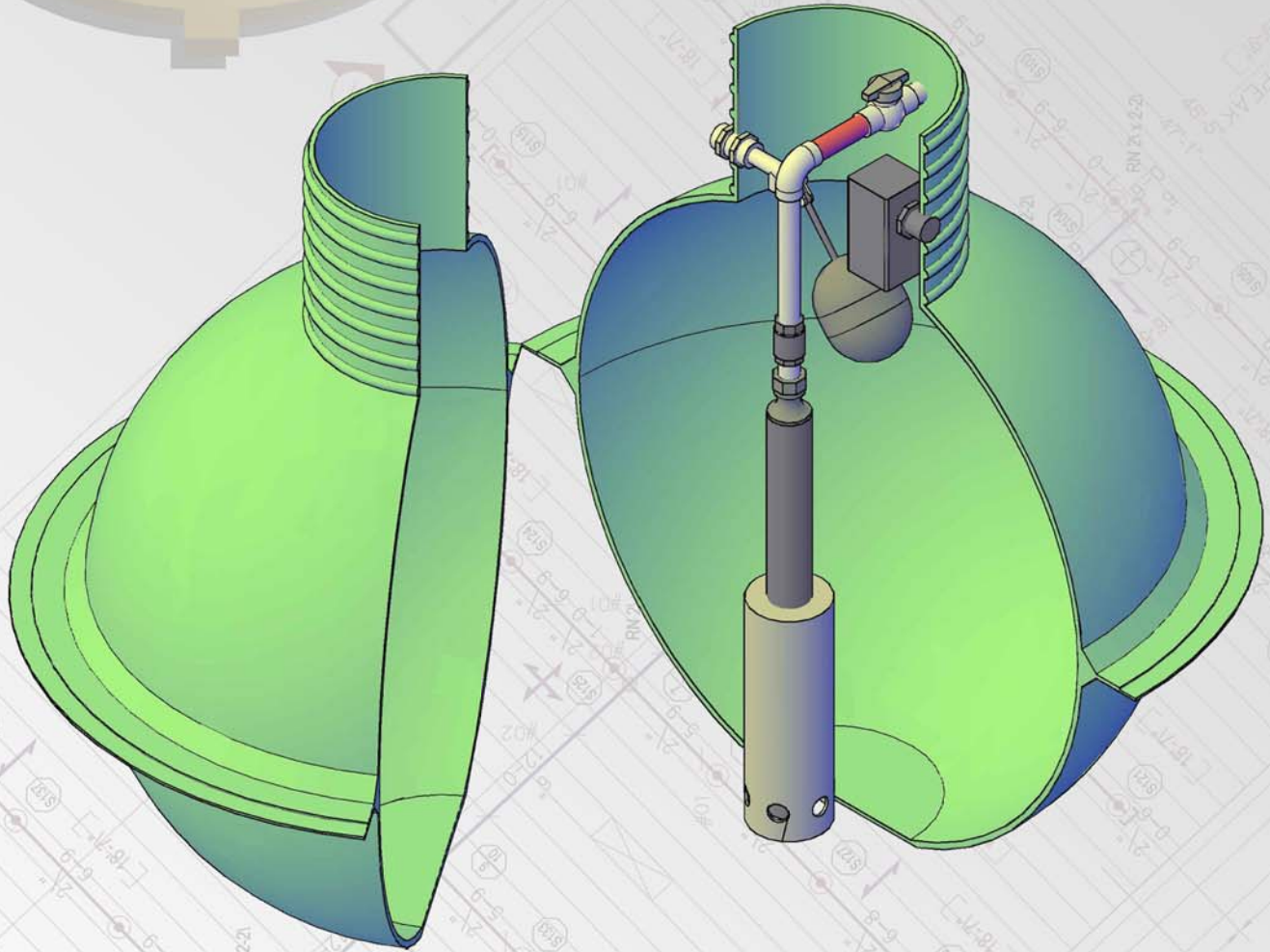

Our UG Packaged Fire Pump System locates an entire residential fire pump system underground, out of sight, and out of mind. Using a submersible pump and electric motor contained in a 500 gallon water storage tank this package delivers imposing performance. UG systems come complete with a full control suite including a water low-level alarm & a pump-run alarm. Capable of flow rates out to 60GPM @ 65PSI this one package will cover the vast majority of NFPA-13D applications. Constructed of corrosion resistant materials our underground system is designed to provide years of reliable, hassle-free service. Just bury it and forget about it, with our UG Packaged System, Talco has you covered.

# TALCO

## Fire Systems

DIESEL - ELECTRIC - INLINE - SPLIT CASE - CENTRIFUGAL - TURBINE - SUBMERSIBLE

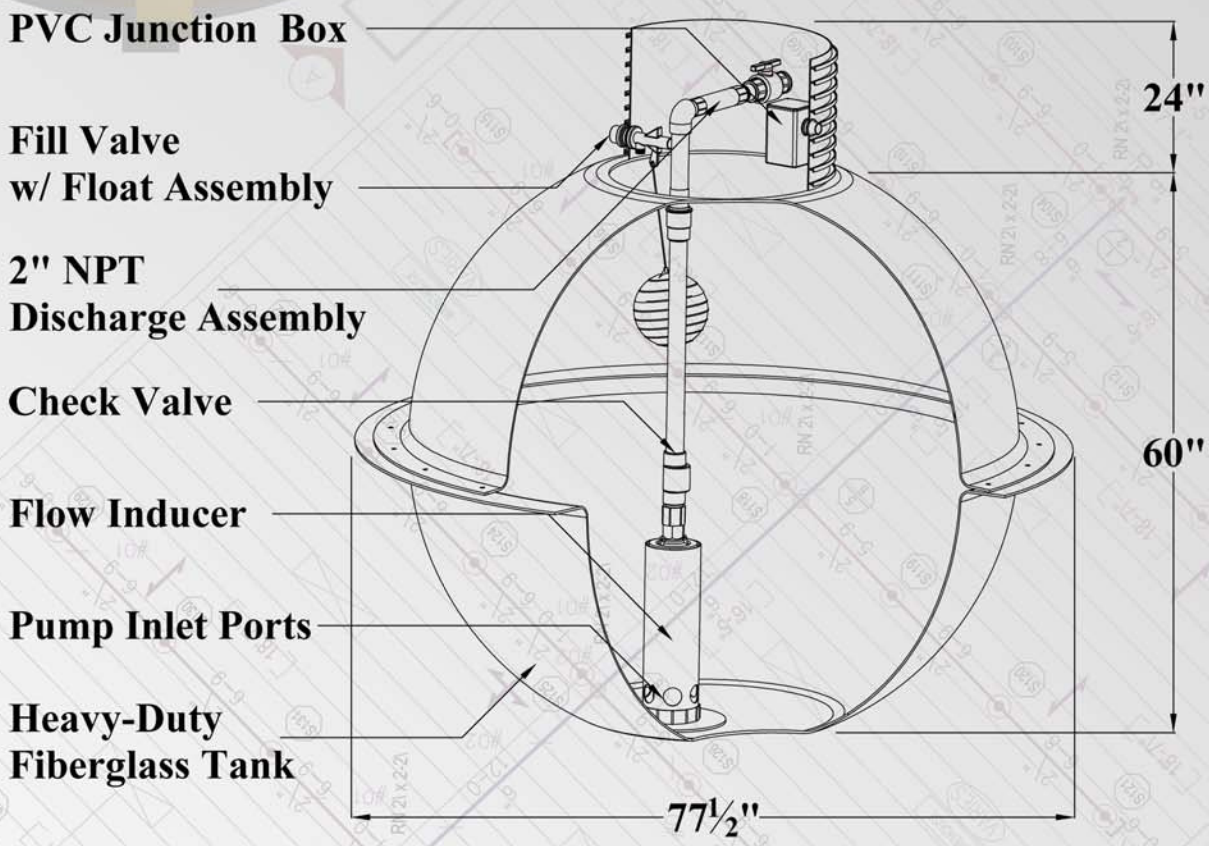

### TALCO 13D Controller w/ Low Level Alarm (for Remote Mounting)

